

SELECTABLE MODE HIGH/LOW/OFF PIR FIXTURE INTEGRATED INDOOR/ MOTION/PHOTO SENSOR

FSP-2X2 SERIES



FSP-202

FSP-212

PRODUCT OVERVIEW

The FSP-2x2 is a family of passive infrared (PIR) outdoor sensors that raise or lower the electric lighting level to high, low or off based on motion and/or daylight contribution. Typically, once the sensor stops detecting movement and the time delay elapses, lights will first fade to low mode, and eventually switch off. When motion is detected, the sensor ramps the light level to high mode unless the daylight contribution is sufficient.

The integral photocell can also switch the lights on and off for dusk to dawn control, so that lighting remains on overnight even without motion detection.

The sensors control 0-10VDC or non-dimming LED drivers or ballasts. The low voltage FSP-202 may be used with dim-to-off drivers or ballasts.

The FSP-212 sensor is not compatible with and should not be used with non-isolated drivers.

Sensor adjustments are made using rotary trimpots located on the sensor.

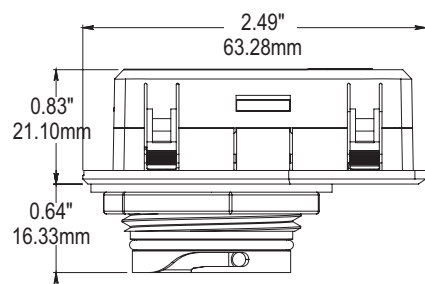

FSP-202 dimensions

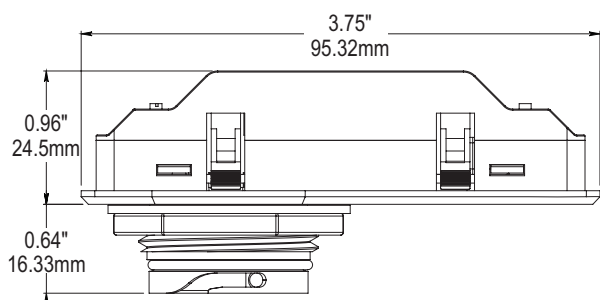
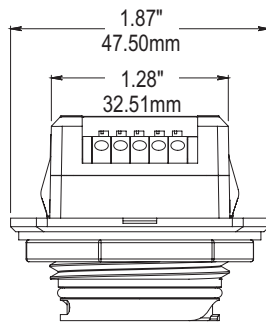

FSP-212 dimensions

MODELS	
FSP-202, 12-32VDC	Use with dim-to-off driver or ballast or with Wattstopper power pack
FSP-212, 120/277VAC, 50/60Hz	
SPECIFICATIONS & FEATURES	
Load Ratings (FSP-212):	
@ 120V 0-800W tungsten, ballast, LED driver; 1/6hp motor	
@ 230-240V 0-300W ballast, LED driver	
@ 277V 0-1200W ballast, LED driver; 1/6hp motor	
Do not use FSP-212 with non-isolated LED drivers	
Current consumption (FSP-202): 10 mA max.	
0-10V sinking current: 50mA	
Three interchangeable lenses for mounting between 8' and 40'	
Choice of 4 operating modes plus service mode	
Adjustable high or low dim level (1 to 10V)	
Adjustable time delay (30 seconds to 30 minutes)	
Adjustable cut off delay (none, 1/2 of time delay)	
Ramp and fade times (2 seconds; 10 seconds)	
Photocell On/Off levels (On 5 fc, Off 10 fc for at least 3 seconds)	
Operating temperature: -40°F to +158°F (-40°C to +70°C)	
Weight: FSP-202, 1.31oz (37g); FSP-212, 2.43oz (69g)	
UL and cUL listed (E101196)	
IP66 rated	
Five year warranty	
MATERIALS	
Polycarbonate	
Flame retardant	
UV resistant	
Impact resistant	
Recyclable	
Meets materials restrictions of RoHS	
FACTORY DEFAULTS	
Control mode:	Mode B
Trim level:	1V
Time delay:	15 minutes

*PEP designation applies to FSP-212 only

COVERAGE

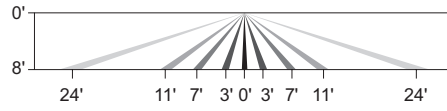
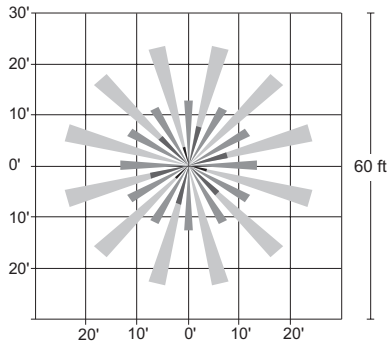

FSP-L2 top and side coverage patterns

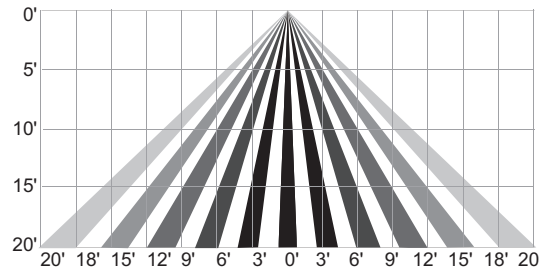
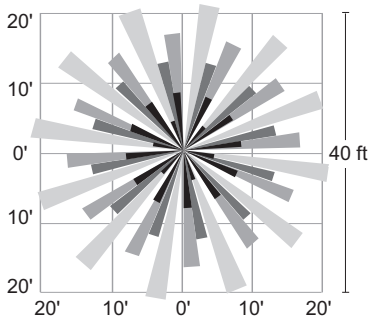

FSP-L3 top and side coverage patterns

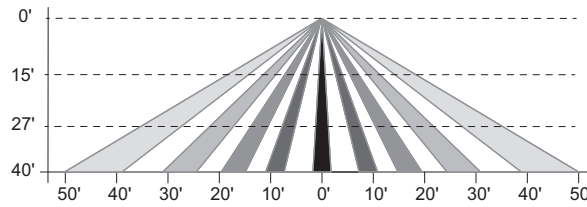
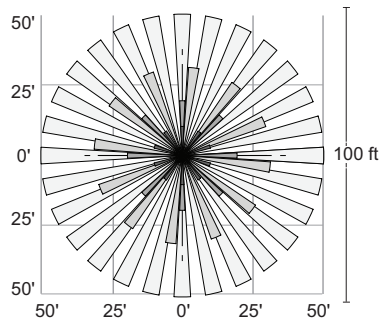

FSP-L7 top and side coverage patterns

DIMENSIONS OF LENS OPTIONS

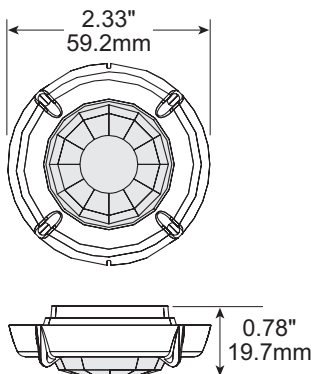

FSP-L2 dimensions

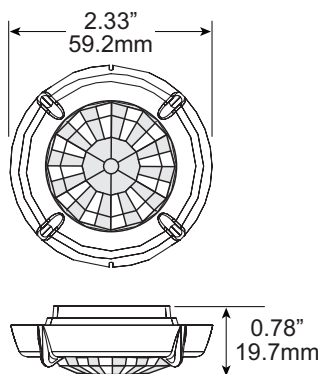

FSP-L3 dimensions

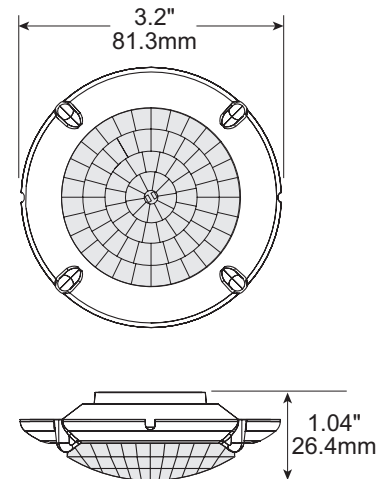

FSP-L7 dimensions

FSP-L2-S, FSP-L3-S, and FSP-L7-S Dimensions

The FSP-Lx-S models include a shroud, which blocks high-angle light coming from the fixture, to improve photocell performance. With the shroud attached, the dimensions for all three lenses are identical

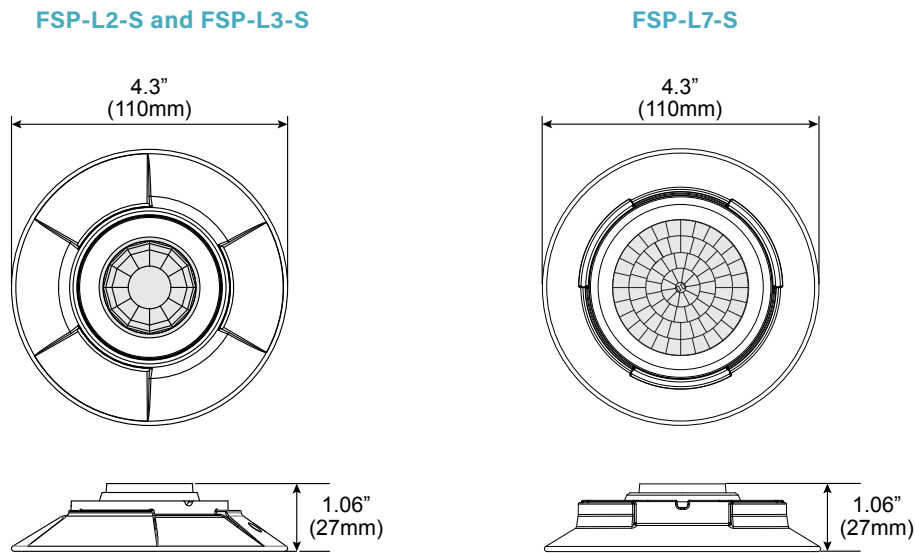

INSTALLING THE FSP-2X2 SENSOR IN LIGHT FIXTURE

1. Determine an appropriate mounting location inside the light fixture. Allow a minimum distance of 0.2" (5.1mm) from the end of the sensor to the wall of the fixture.
2. Drill a 1.30" (33mm) diameter hole through the sheet metal in the bottom of the fixture.
3. Place the rubber gasket on the threaded collar, and install the sensor face down, parallel to the mounting surface. Ensure the rubber gasket touches the inside surface of the fixture. Install the collar and torque to 25-30 in-lbs to maintain IP rating.
4. Align the locking features between the sensor and lens module and push the lens module forward until the O-ring seals firmly. Turn the lens module clockwise to lock in place.
5. Connect load, supply and control wires.
6. Restore power from the circuit breaker.

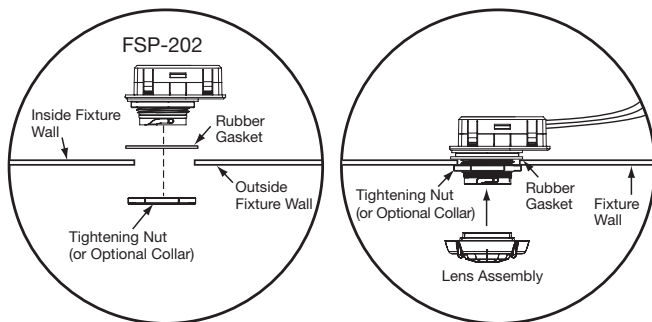

Figure 1. Installing the FSP-202 in the light fixture

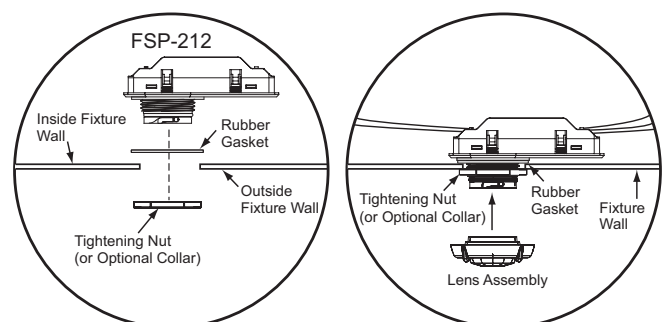

Figure 2. Installing the FSP-212 in the light fixture

NOTE: The outside fixture wall thickness should be no greater than 0.125" (3.18mm) for optimal sensor mounting and security.

WIRING DIAGRAMS FOR LOW VOLTAGE FSP-202 SENSORS

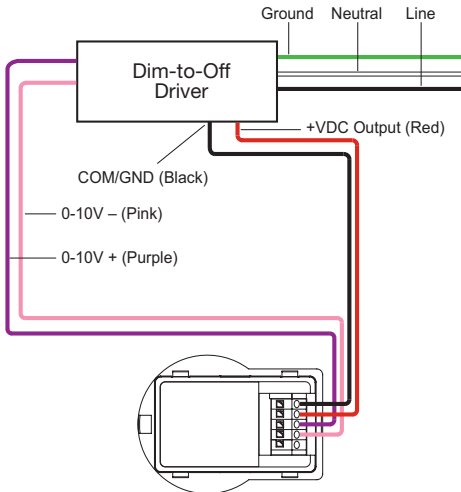

Figure 3. FSP-202 wiring with dim-to-off ballast or LED driver

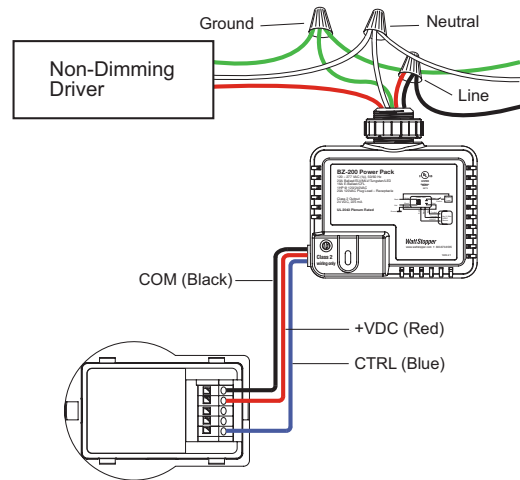

Figure 4. FSP-202 wiring with non-dimming ballast or LED driver and power pack for on/off control

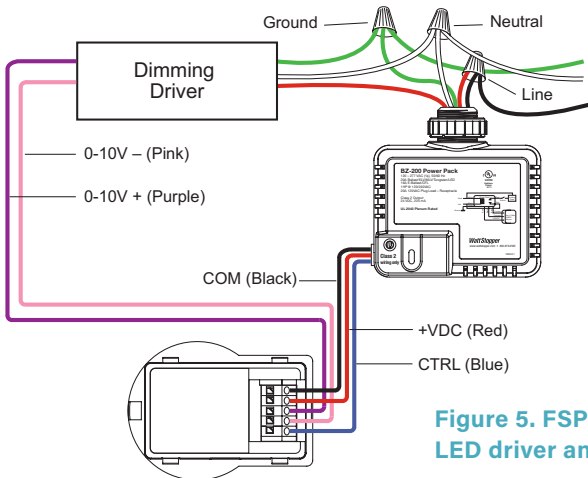

Figure 5. FSP-202 wiring with dimming ballast or LED driver and power pack for on/off control

WIRING DIAGRAMS FOR LINE VOLTAGE FSP-212 SENSORS

NOTE: The FSP-212 is not compatible with non-isolated LED drivers.

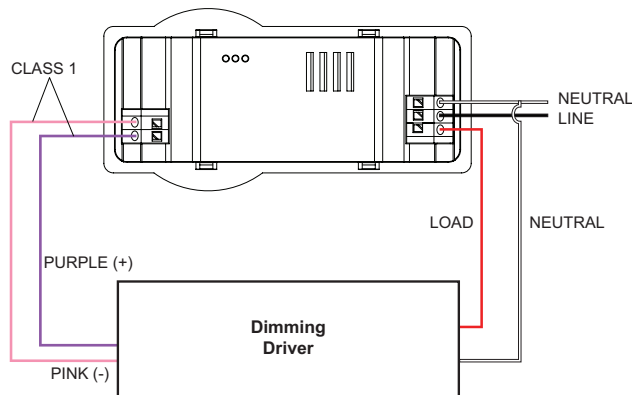

Figure 7. FSP-212 wiring with dimming ballast or LED driver

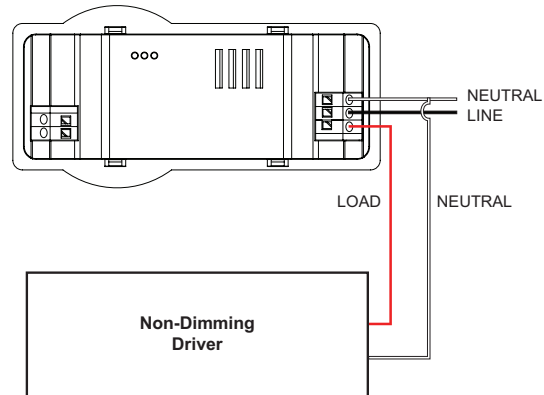

Figure 8. FSP-212 wiring with non-dimming load

ADJUSTING THE SENSOR VIA CONTROL MODES

The FSP-2x2 has five selectable modes, each of which has preset parameter settings. Once the mode is selected, you have the ability to further customize operation by adjusting the Dim and the Time pots. The sensor also has a test mode.

Select the **Mode** and, if needed, adjust the other pots using a small screwdriver. (Mode functionality is explained on the following page. Note: A sixth mode, Test mode, is accessed automatically when mode C is selected).

Dim (High/Low) – This pot adjusts either the low dim level (for modes A, B, and C) or high dim level (for mode D).

When the Dim pot is turned, the load goes to the current dimming level, allowing visual confirmation of the dim level. After the Dim pot has not moved for 3 minutes (this allows time to reattach the lens to the sensor), the load will go to the maximum level for 10 seconds and then turn OFF for 10 seconds. The load then returns to previous state before trimpot adjustment. This process allows auto calibration of the photocell, for daylight control.

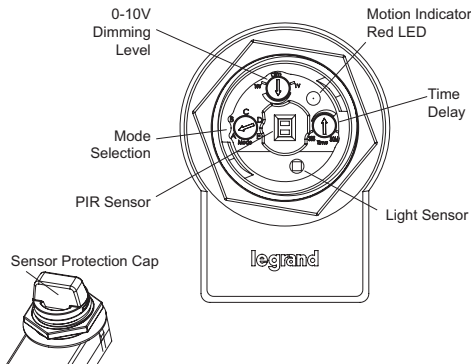

NOTE: Remove Cap before use

FSP-202 sensor module

Time – This pot sets the amount of time after vacancy is no longer detected before the loads go to either the Low Trim value or turn OFF, depending on the mode. Additionally, for Modes B and C, this controls the amount of time before the load goes from the Low Trim to OFF. The time will be half of the initial delay. For example, if time is set to 20 minutes, the load will go from ON to the Low Trim level 20 minutes after occupancy is no longer detected. The the load will then turn OFF 10 minutes after it goes to the Low Trim level.

Daylighting Control – The FSP-2x2 has a photocell which measures the ambient light to determine daytime/night time, for use in modes A, B, and D. Once the sensor registers enough ambient light to indicate daylight, it triggers daylight control.

Fade Time – For all modes, the fade up time from OFF to ON or OFF to High Dim Level is 2 seconds, and the fade down time from ON to Low Dim Level or Low Dim Level to OFF is 10 seconds.

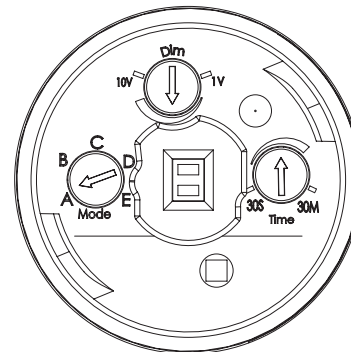

Control pot detail

CONTROL MODE SEQUENCES OF OPERATION

Mode A - Outdoor Parking Area with Minimum Light Level at Night

Features: Always ON during the night (ON at dusk; Low Dim maintains minimum level overnight; OFF at dawn)

When the ambient lighting is below daylight on level (5 footcandles), the load is always ON. If occupancy is detected, the loads turn ON at 10V. Once no occupancy is detected, the load will go to the trim level set with the Dim pot, once the Time delay expires. When ambient lighting rises to the daylight off level (10 footcandles) for at least 3 seconds, the load will turn OFF.

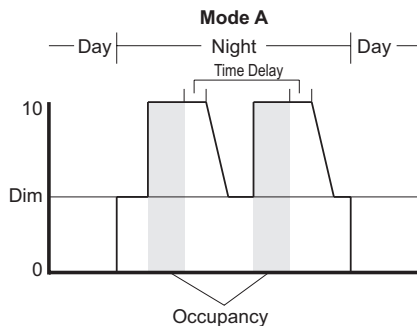

Mode B - Outdoor Parking Area with High/Low/Off Levels at Night

Features: At dusk, turns ON with occupancy; Drops to Low Dim level after vacancy, then turns OFF after delay; OFF at dawn

When the ambient lighting is below daylight on level (5 footcandles) and occupancy is detected, the sensor turns the loads ON at 10V. Once no occupancy is detected, the load will go to the trim level set with the Dim pot after the Time delay expires. As long as the area remains unoccupied, the load stays at the trim level for 1/2 of the Time delay, and then turns OFF. Once ambient lighting rises to the daylight off level (10 footcandles) for at least 3 seconds, the load will turn OFF.

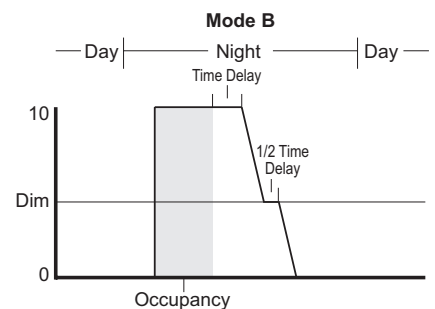

Mode C - Indoor Parking Structure or High-Bay with No Daylight Control

Features: High/Low/Off Levels - Day or Night

This mode is similar to mode B, except that there is no daylight control.

Therefore, anytime, occupancy is detected, the load turns ON at 10V.

Once no occupancy is detected, the load will go to the trim

level set with the Dim pot after the Time delay expires. As long as the area remains unoccupied, the load stays at the trim level for 1/2 of the Time delay, and then turns OFF.

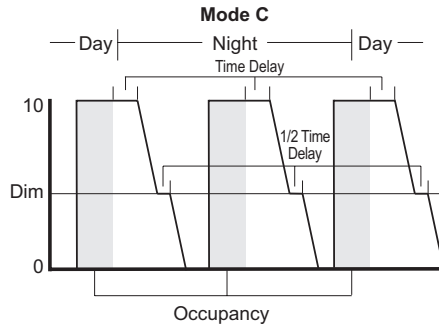

Mode D - Indoor Parking Structure or High-Bay

Features: At dusk, turns ON with occupancy; High Dim level sets Maximum ON level; OFF at dawn

When the ambient lighting is below daylight on level (5 footcandles) and occupancy is detected, the load turns ON at the trim level set with the Dim pot. Once no occupancy is detected, the load will turn

OFF. Once ambient lighting rises to the daylight off level (10 footcandles) for at least 3 seconds, the load will turn OFF.

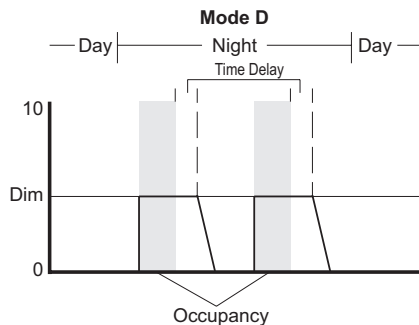

Mode E - Service Mode

Features: Allows visual adjustment of Dim level

If the Time pot is set at maximum, the load turns ON at the current Dim level. If the Time pot is set at minimum, the load turns OFF.

Note that after turning the Time pot to change the ON/OFF setting, the unit will not respond to further changes for 3 seconds.

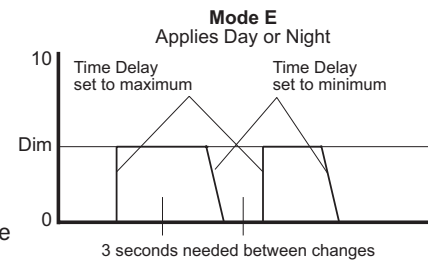

Test Mode - Temporarily reduces time delay to 5 seconds to allow testing of occupancy sensor

Whenever mode C is selected, the FSP-2x2 will enter Test mode for 5 minutes. If the sensor is currently in mode C, selecting another mode and then returning to mode C will restart Test mode. During Test mode, daylight control is not active and the value of the Time pot is overridden. When occupancy is detected the load will turn ON at 10V. After 5 seconds without occupancy detection, the load will go to the Dim level for 2.5 seconds and then turn OFF. After 5 minutes, the unit will revert to normal Mode C operation.

	Daylighting Control	High/Low Dim	Time Delay	Auto On	Auto Off
Mode A	Yes	Low Dim	30sec - 30 min	Ambient light level below 5 fc	Ambient light level above 10 fc
Mode B	Yes	Low Dim	30sec - 30 min; 1/2 of set value during Low Trim	Ambient light level below 5 fc and occupancy detection	One half time delay expired or ambient light level above 10 fc
Mode C	No	Low Dim	30sec - 30 min; 1/2 of set value during Low Trim	Occupancy detection	One half time delay expired
Mode D	Yes	High Dim	30sec - 30 min	Ambient light level below 5 fc and occupancy detection	Time delay expired or ambient light level above 10 fc
Mode E	No	Low Dim	N/A	Load is ON at Dim level when time delay trim in maximum position	Load is OFF when time delay trim in minimum position

ORDERING INFORMATION

Catalog #	Master Pack Details					Inner Pack Details				
	Master Pack Quantity	Case dimensions (inches)			Weight (pounds)	Inner Pack Quantity	Case dimensions (inches)			Weight (pounds)
		Length	Width	Height			Length	Width	Height	
FSP-202	200	21.14	19.72	10.31	22.16	100	20.67	9.5	9.8	10
FSP-212	200	21.14	19.72	10.31	36.27	100	20.67	9.5	9.8	16.4
FSP-L2	400	16.14	15.35	18.74	21.6	100	15.5	7.32	8.6	4.82
FSP-L3	400	16.14	15.35	18.74	20.3	100	15.5	7.32	8.6	4.82
FSP-L7	100	23.82	16.22	9.69	10.74	50	23.03	7.72	8.58	4.72

Catalog #	Color	Description	Voltage
<input type="checkbox"/> FSP-202	White	Fixture mount, passive infrared motion sensor, low voltage	12-32 VDC
<input type="checkbox"/> FSP-212	White	Fixture mount, passive infrared motion sensor	120-277VAC, 50/60Hz
<input type="checkbox"/> FSP-L2	White	360° lens, maximum coverage 48' diameter from 8' height	
<input type="checkbox"/> FSP-L2-B	Black		
<input type="checkbox"/> FSP-L2-BR	Brown		
<input type="checkbox"/> FSP-L2-G	Grey		
<input type="checkbox"/> FSP-L2-S	White		
<input type="checkbox"/> FSP-L3	White	360° lens, maximum coverage 40' diameter from 20' height	
<input type="checkbox"/> FSP-L3-B	Black		
<input type="checkbox"/> FSP-L3-BR	Brown		
<input type="checkbox"/> FSP-L3-G	Grey		
<input type="checkbox"/> FSP-L3-S	White	360° lens, maximum coverage 40' diameter from 20' height, with shroud; Minimizes high-angle light contribution to photocell	
<input type="checkbox"/> FSP-L7	White	360° lens, maximum coverage 100' diameter from 40' height	
<input type="checkbox"/> FSP-L7-B	Black		
<input type="checkbox"/> FSP-L7-BR	Brown		
<input type="checkbox"/> FSP-L7-G	Grey		
<input type="checkbox"/> FSP-L7-S	White		
<input type="checkbox"/> FSP-C1-W	White	Small collar, for use with FSP-L2 and FSP-L3 lenses (Optional aesthetic collar to transition from fixture housing to lens) Note: Not used with lenses that include shroud	
<input type="checkbox"/> FSP-C1-B	Black		
<input type="checkbox"/> FSP-C1-BR	Brown		
<input type="checkbox"/> FSP-C1-G	Gray		
<input type="checkbox"/> FSP-C2-W	White		
<input type="checkbox"/> FSP-C2-B	Black		
<input type="checkbox"/> FSP-C2-BR	Brown		
<input type="checkbox"/> FSP-C2-G	Gray		

Note: Unless used with a driver or ballast with a low voltage power supply, the FSP-202 requires a Wattstopper power pack (ordered separately) to operate. FSP-Lx series lens required for operation; order lens separately.

Information supplied above is subject to change.
Harmonization code: 8538908080. Country of origin: China.

27430r2 Rev 04/2021